

Tray base/turret (2 pages)

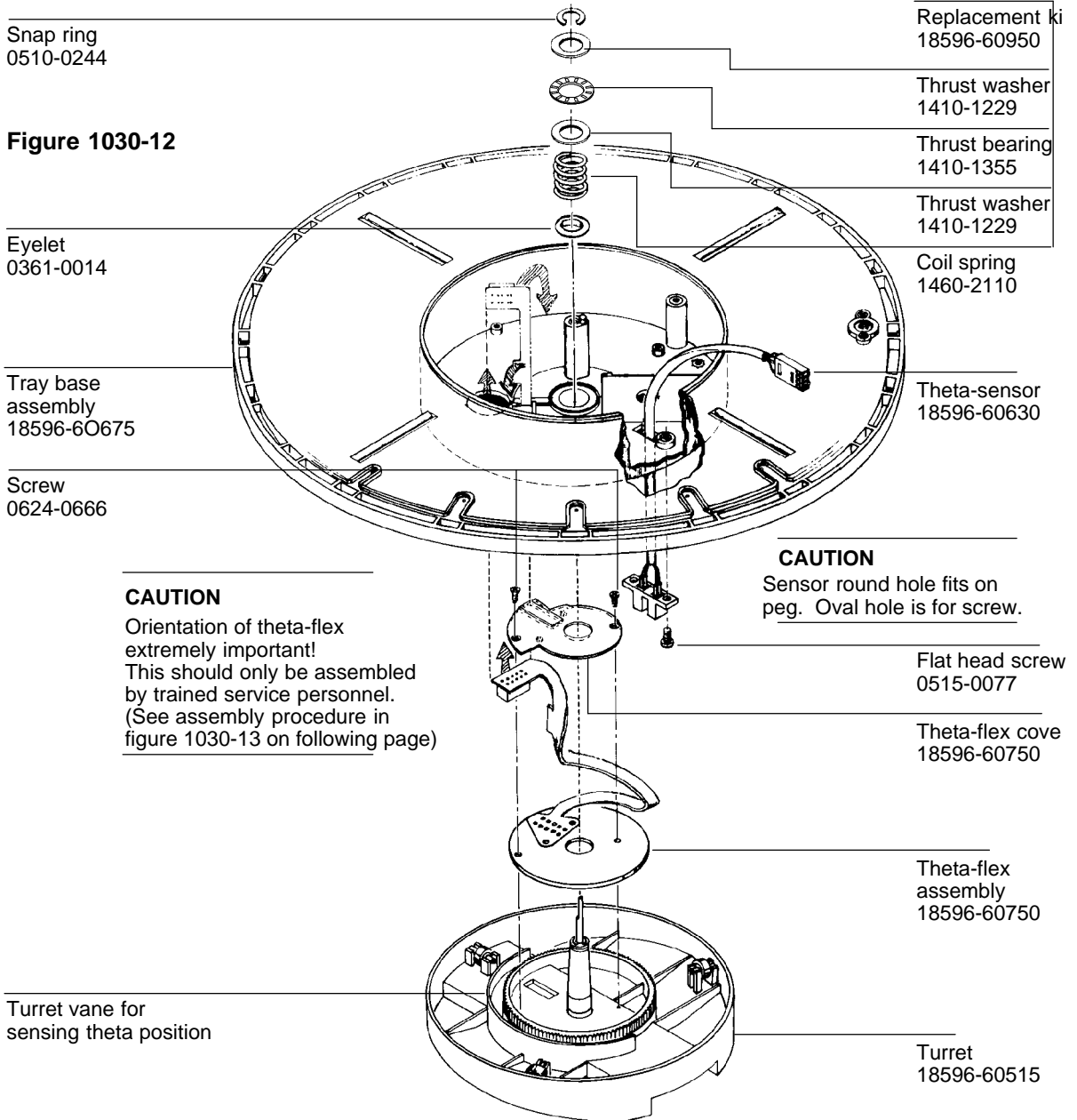

Theta-flex assembly procedure

Figure 1030-13

1

Turn the turret so that the J1 connector is on the left.

Unwind the theta-flex 3/4 of a turn.

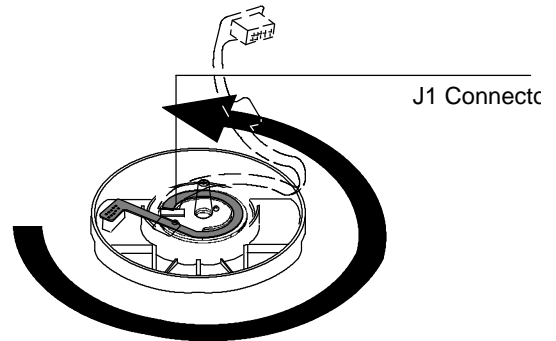

2

Turn the tray base so that the drain hole is at the front.

Thread the J2 connector through the tray base.

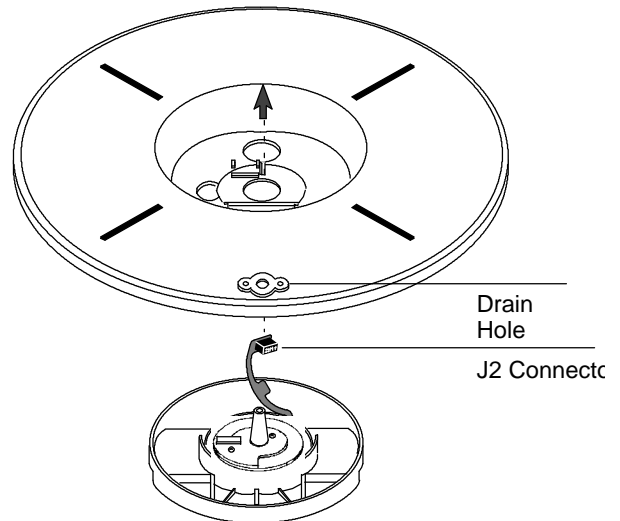

3

Place the square tab of the theta-flex within the ridges inside the base.

